

POWER FACTOR CORRECTION AND HARMONIC CURRENT REDUCTION IN DUAL FEEDBACK PWM CONTROLLED AC/DC DRIVES.

¹RAJENDRA PANDAY , ²C.VEERESH,ANIL KUMAR
CHAUDHARY

^{1,2}Mandsaur Institute of Technology,Mandsaur, INDIA
E-mail: rajendrapanday28@yahoo.in

Abstract- The electrical power industry has grown rapidly and loads are changing from simple, non-electronic loads to electronic ones. These electronic loads draw a non-sinusoidal current even when the supply voltage is perfectly sinusoidal. In this paper PWM controller with dual feedback loop with simple single-stage single-switch input-current shaping circuit was designed, simulated and tested for AC/DC drives which generates input current harmonics due to its non-linear characteristics. A sinusoidal input current with nearly unity distortion factor was achieved through current harmonics reduction by using PWM boost regulator. The circuit utilizes the charging and discharging increments of boost inductor current to shape a sinusoidal input current. Inductor current was controlled by means of PWM controller. The controller accepts two feedback signals, the first is the inductor current and the other is the output voltage of the AC/DC drives. The simulation results of fast Fourier transform (FFT) show the great reduction in current harmonic which in turns tends to a great improvement in power factor and the sinusoidal shape of input current and hence overall performance of AC/DC drives.

Index Terms—Current harmonics, Current shaping, Power factor, PWM controller, voltage regulation.

I) INTRODUCTION

With great advance of power semiconductor switching devices and their related control circuits, high frequency switching power converters can be implemented for power electronic appliances. In these converters, pulse width modulation (PWM) technique is widely used [1, 2]. On the other hand, to improve power factor in utility AC/DC drives a variety of power factor correction (PFC) Converters are effectively introduced. Currently, the electrical power industry has grown rapidly and loads are changing from simple, non- electronic loads such as tungsten lamps, motors, relays and resistive heaters to electronic ones such as fluorescent lamps, motors with solid-state drivers and industrial drives. These electronic loads draw a non-sinusoidal current even when the supply voltage is perfectly sinusoidal [5] are the major sources of excessive current harmonics. The current harmonics has a significant effect on customer loads in a form of heating, distortion or operation malfunction. Harmonic disturbances are the most researched part of all power quality disturbances, especially over the past two decades. The interest in harmonics research can largely be attributed to the advance in power electronics technologies, and this driven by the desire to have more energy efficient equipment and greater control of equipment operation. Input-current shaping, power factor correction PFC and harmonics reduction technologies are all inherently related to each other and can be essentially classified into two main categories 1) Active methods and 2) Passive methods. The first technology use switching circuits controlled

actively. Some of active technologies based on harmonics-injection techniques and called active filters. The active filter senses the harmonics distortion, and injects currents that are 180 degrees out of phase with the harmonic frequencies that exist in the system. They have a distinct advantage that they do not resonate with the system. They can be used in very difficult circumstances where passive filters cannot lies. They can also address more than one harmonic at a time and combat other power quality problems such as flicker [8]. Another active technique are based on DC-DC switching converters filters that usually applied to the circuits that contain AC to DC converter such as DC motor drive, switched mode power supply and battery chargers. In these types of current wave shaping technique, line current is forced to follow the sinusoidal line voltage. A controlled high frequency pulse width modulation (PWM) applied on the DC-DC converter which is the main component of the circuit. The second methods are simply based on the use of RLC filter that offer a low impedance path for unwanted current harmonics and drive it back away from the load under consideration. These filters have no switches and hence no electromagnetic interference emissions EMI. Beside that it is very simple, robust and has low cost of implementation. However, their performance lower when compared to active circuits, they are heavy bulky specially when designed for low harmonics mitigations. Passive filters are employed either to shunt the harmonic currents off the line or to block their flow between parts of the system by tuning the elements to create a resonance at a selected harmonic frequency [6, 7].

Standardization activities in this area of harmonics limitation have been carried out for many years. As early as 1982, the International Electrotechnical Committee -IEC published its standard IEC 555-2, which was also adopted in 1987 as European standard EN 60555-2, by the European Committee for Electrotechnical Standardization -CENELEC. IEC 555-2 standard has been replaced in 1995 by standard IEC 1000-3-2, also adopted by CENELEC as European standard EN 61000-3-2 (IEC Standards 1998). The standard IEC 1000-3-2 applies to equipment with a rated current of up to and including 16A rms per phase which is to be connected to 50Hz or 60Hz, 220-240Vrms single-phase, or 380-415Vrms three-phase mains [9, 10]. Active power filters are more and more capturing the interest of researchers and industries owing to the decreasing quality of power supplied by the electrical distribution companies and the difficulties in fulfilling the constraints imposed by national and international standards only by using traditional compensating strategies [3, 4]. The use of active systems for compensating harmonic distortion and reactive power in the supply electrical networks, both at user level or at a higher voltage level, is now more often preferred to the classical passive compensating methods. In fact active filters do not present all the typical drawbacks of passive systems such as the detuning of single tuned filters due to changes of system operative conditions and surrounding environment or the generation of resonance at particular frequencies, between the network and filter reactance, that amplifies unwanted harmonics [13,14].

II) THE PROPOSED CIRCUIT

A sinusoidal input current with nearly unity distortion factor was achieved through current harmonics reduction by using PWM boost regulator. The circuit utilizes the charging and discharging increments of boost inductor current to shape a sinusoidal input current. Inductor current was controlled by means of PWM controller. The controller accepts two feedback signals, the first is the inductor current and the other is the output voltage of the AC/DC converter. The proposed PWM controller with dual feedback loop with simple single-stage single-switch input-current shaping circuit is designed for AC-DC converter and it considered as nonlinear load. This circuit is essentially based on boost DC-DC regulator with high frequency PWM controller. The controller gets two control signals and generates the PWM switching pulses accordingly as shown in figure(1).

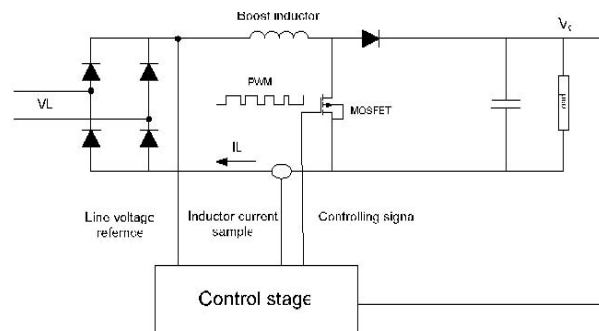

FIG 1) Dual loop PWM controller circuit

Feeding the input current reference signal and the DC voltage ripple reference into the switching controller will yield both harmonic reduction and DC voltage regulation. The principle of operation for DC-DC switching regulator harmonic filtering is related to the topology of DC-DC converter through which PWM is performed. Among the different power regulators topologies boost converter shown in figure (1) is the most suitable one, where the boost inductor is in series with the ac power line. This result in minimum conducted electromagnetic interference (EMI) at the line when the circuit operates in continuous conduction mode (CCM) [11].

For our boost regulator topology, the input current shaping is performed by controlling the amplitude of boost inductor current, and this in turns is done through the controlling or the modulation of switching pulses. When the boost switch is turned ON, the inductor current tends to rise due to charging of boost inductor, and when the switch turned OFF, the inductor current will decay down by discharging through boost capacitor. The rise increment is given by equation. (1) [12]. These increments up and down of boost inductor current are the key of current shaping.

$$\Delta i_L = \frac{\sqrt{2} v(t) D}{L F_s} \quad (1)$$

where

$\Delta i_L =$ Increment in inductor current

$v(t) =$ Instantaneous phase voltage

$D =$ Duty cycle of boost switch

$L =$ Boost inductor

$F_s =$ Switching frequency of boost converter

III) DESIGN OF PROPOSED CIRCUIT

A) POWER STAGE DESIGN:

The parameters of the designed power stage are listed in Table.1, in which the converter parameter include boost inductance boost capacitance, input line voltage, DC output voltage and rated power.

3.1. Boost capacitance

The capacitance was calculated using the formula in equation 2. [12],

$$C_{OUT} = \frac{2Pt_{HLD}}{V_1^2 - V_2^2} \tag{2}$$

Where C_{OUT} is Boost capacitance, P is Rated output power, t_{HLD} is holdup time, V_1 is capacitor voltage at the beginning of t_{HLD} , V_2 is Capacitor voltage at the end of t_{HLD} .

The parameters that affect the choice of the boost capacitance include:

- i) Holdup time capability which is the amount of time at rated output power that will take the capacitor voltage to discharge to a minimum operating voltage.
- ii) Output DC ripples current for holdup time of 20 ms, V_1 at the rated output DC voltage, V_2 of 290 V and rated power of 1 KW, the boost capacitance is calculated to be 6200uF.

3.2. Boost inductance

It is one of the keys components in the design. The value of this inductor significantly affects the ripple current due to switching operation of boost converter. Inductance value was calculated to give an acceptable level of peak to peak ripple current which is chosen between 10% and 20% of the input current peak value. The value of boost inductance also affect the regulator's mode of operation, higher inductance value moves the regulator to work in discontinues conduction mode DCM mode where the current does reach the zero level which not preferred due to its EMI pollution. Equation (1) can be used to calculate boost inductance For the values of line voltage = 110 V rms, output DC voltage = 300 V, input current = 9.82 A rms and switching frequency of 20 K Hz, the inductance value is calculated and found to be 1 mH.

Table.1 Parameters of the designed power stage

Parameter	Value
line voltage	110 V rms
DC output voltage	300 V
Motor power	1 KW
Boost inductance	1 mH
Boost capacitance	6200 uF

B) PWM CONTROLLER DESIGN

PWM controller responsible of generating switching pulses for boost regulator to perform two functions; sinusoidal current shaping and maintaining constant and stable output voltage. For this reasons the controller is designed with two feedback signal, one from output voltage of the converter and the other from input line current which is equivalent to boost inductor current as shown in figure (3). Low pass filter is used to control the output ripple voltage of the converter and the reference voltage is used to select the required level of output voltage. Sinusoidal reference is taken as pattern over which the line current is shaped. Gains are used to modify the signal

to next controlling stage. The error signal that used as an input for gate driver is generated from comparing the boost current with modified sinusoidal reference after the product. Gate driver generate positive pulse when the error is positive and zero Voltage When the error is negative and it works as PWM modulator.

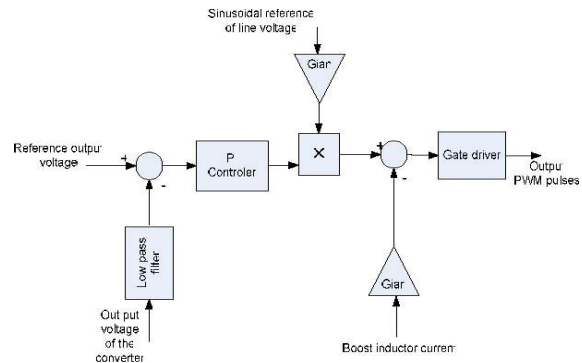

Figure.2 PWM controller with two feedback loops

IV). SIMULATION RESULTS

Simulink model was used to simulate a PWM controller with dual feedback loop with simple single-stage single-switch input-current shaping circuit for single phase AC/DC drives. The fast Fourier Transform FFT analysis was applied to calculate the harmonic content of the input current before and after input-current shaping. In figure(3), the inductor current (input current) appears as saw tooth due to charging and discharging phases of boost inductance. The conduction point between charging and discharging is kept at none zero value which indicates that the converter works in CCM. Figure (4) shows the input line current after the input-current shaping, it is clear that the current tends to rush up at the beginning of operation for a part of half cycle. This is because the output capacitor is empty of charge and works as short circuit at that point. This problem can be solved by using a soft starting circuit which is out of our scope this paper.

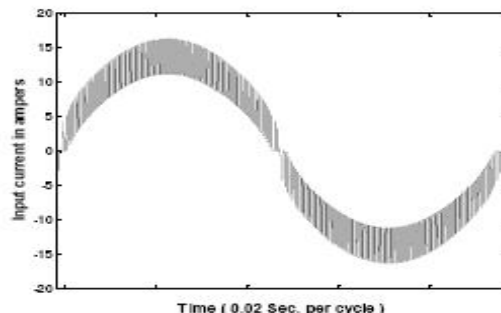

Figure. 3 Inductor current made of charging and Discharging phases

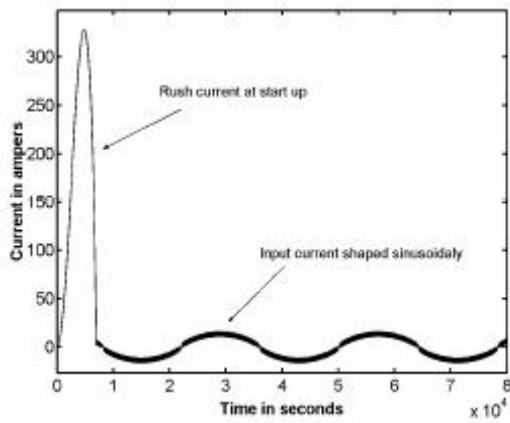

Figure. 4 Shows the input line current after input-current Shaping

V, 3.9 V and 2.02 V respectively. Exact odd harmonic levels are listed in Table 2. Different RMS values of input current are given in Table 3.

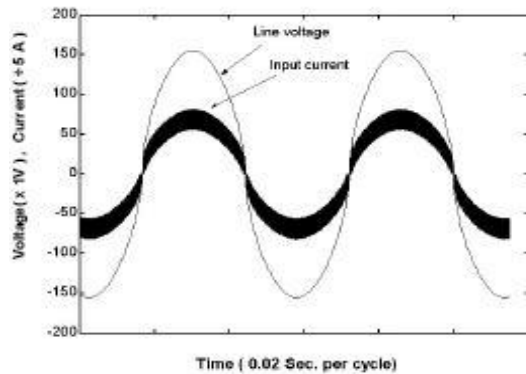

Figure. 5: Shows the input current plotted over the line voltage.

Figure (5) shows the input current plotted over the line voltage. The plot shows clearly a significant Table2. Significant odd harmonics levels prior to the sinusoidal line voltage. The proposed circuit achieves unity displacement factor that can be noted from zero phase difference between current and voltage. Also it achieves near unity distortion factor due to small harmonics contents of input current and this can be noted visually from a sinusoidal shape of the current and numerically for the result of FFT analysis. The FFT analysis was applied to the input line current generated by the Matlab simulation model. Analysis was performed before and after input-current shaping. The harmonics plot prior to the input-current shaping is shown in figure (6). The AC/DC converter without input-current shaping is composed of bridge rectifier followed by boost regulator work at operating frequency of 2 KHz; duty cycle is calculated to maintain the out put voltage at 300V. The results show that the boost regulator works at DCM with current down at fraction of line voltage cycle. This leads to a significant 3rd up to 7th harmonics of 12.59 V, 3.9 V and 2.02 V respectively. Exact odd harmonic levels are listed in Table 2. Different RMS values of input current are given in Table 3.

Table 2. Significant odd harmonics levels before and after input- current shaping

Harmonic Order	1 st	3 rd	5 th	7 th	11 th	19 th
Harmonic Amplitude in A prior input current shaping	21.5	12.59	3.9	2.02	1.19	0.86
Harmonic Order	1 st	3 rd	7 th	11 th	15 th	19 th
Harmonic amplitude in A after input current shaping	14	0.27	0.83	0.67	0.54	0.26

Table 3: RMS values of the current before and after input-current shaping

RMS values	Total RMS Current	Fundamental RMS Current	Harmonics RMS Current
Before input-current shaping	17.98 A	15.22 A	9.58 A
After input-current shaping	10.17 A	10.07 A	1.43 A

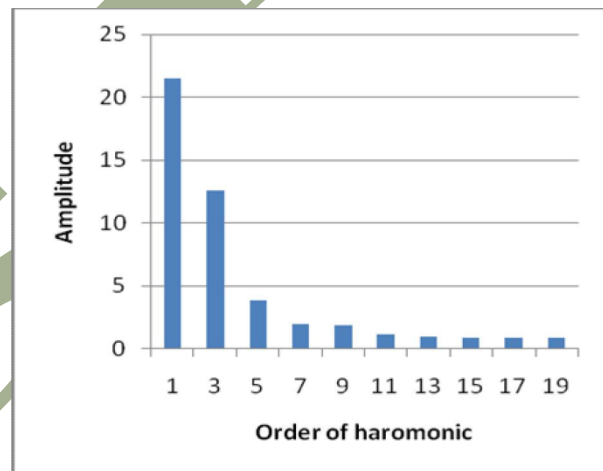

FIG 6 Odd harmonic plot before input current shaping.

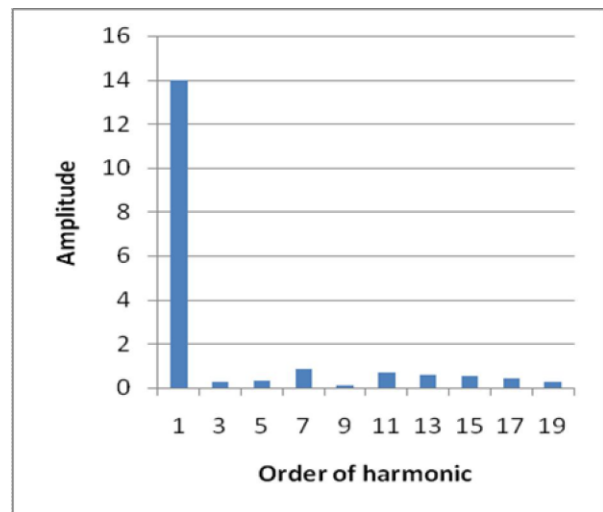

FIG 7 Odd harmonic plot after input current shaping.

Input-current shaping is achieved by using inherent boost DC-DC switching regulator in which harmonics levels were significantly reduced. Figure (7) shows the odd harmonics plot after input-current shaping. Exact odd harmonic levels are listed in Table 2

.Different RMS values of input current are given in Table 3. The significant 3

mitigated from 12.53 V, 3.9 V and 2.02 V to 0.27 V, 0.55 V and 0.83 V. The harmonic of higher frequencies in the range of switching frequency of DC-DC boost regulator can be filtered easily with small shunt capacitor. Harmonics reduction results in a huge improvement in the shape of current waveforms and the power factor improved from 84.64 % to 99.01 %.

V).

CONCLUSION

Simulink model of PWM controller with dual feedback loop with simple single-stage single-switch input-current shaping circuit has been proposed for AC/DC drives. The design circuit has achieved both output voltage regulation and input-current shaping with two feedback signal from output voltage and input current. Simulation was performed and shows good result in input-current shaping (harmonic reduction) and output voltage regulation. Harmonics mitigation results in a huge improvement in power factor which improved from 84.64% to 99.01%. Thus there is an improvement in overall performance.

VI).

REFERENCES

- [1] John N. Chiasson, Leon M. Tolbert, Keith J. McKenzie, and Zhong Du, "A Complete Solution to the Harmonic Elimination Problem," *IEEE Transactions on Power Electronics*, vol. 19, no.2, March 2004, pp.491- 499.
- [2] GYU-HA CHOE, and MIN-HO PARK, "A New Injection Method for AC Harmonic Elimination by active power filter," *IEEE Transactions on Industrial Electronics*, vol.35, no.1, February 1988, pp.141-147.
- [3] Murat Kale, Engin Ozdemir. "A Novel Adaptive Hysteresis Band Current Controller for Shunt Active Power Filter," *Control Applications, Proceedings of 2003 IEEE Conference on*, vol.1, 23-25 June 2003, pp.1118 – 1123.
- [4] Wang Jianze; Peng Fenghua; Wu Qitao; Ji Yanchao; Yaping Du; "A novel control method for shunt active power filters using SVPWM". *Industry Applications Conference, 39th IAS Annual Meeting of IEEE*, vol.1, 3-7 Oct. 2004, pp.129-134.
- [5] Tristan, A. K., P.E., 1999. Distortion and power factor of nonlinear loads. *LTK Engineering Services: 0-7803-5533-4/99/\$10.00*.
- [6] Bernard, S., 1995. "Harmonics Pollution. <http://www.powersquality.com/art0041>."
- [7] Akagi, H., 1996. "New trends in active filters for power conditioning". *IEEE Transaction on Industry Applications*.
- [8] IEC 1000-3-2 (1995-3) Ed.1, 1995. "Electromagnetic compatibility (EMC) -part 3-2: limits - limits for harmonic current emissions (equipment input current ≤ 16 a Per phase)". *IEC*.
- [9] Zhou, C., Raymond B. R. & Fred C. L. 1990. "Design and analysis of a hysteretic boost power factor correction circuit".
- [10] Phillip C. T., 1999. "Boost power factor corrector design with the UC3853 ". ©, Texas Instruments Incorporated.
- [11] Fairchild, 1997. "Theory and application of the ML4821 average current mode PFC controller ". REV 1: 0 10/25/2000.
- [12] Harding, J., "Off-line power supply using the farm ac front-end module ". Vicor Corporation. Applications Engineer: 800.927.9474
- [13] D.M.Divan, "Resonant DC-link Converter -A New Concept in Static Power Conversion," *IEEE-IAS Conference Proceedings 1986*, pp.267-280, 1986.
- [14] A.Cheriti et al., "A Rugged Soft Commutated PWM Inverter for AC Drives," *IEEE PESC'90, Conference Records 1990*, pp. 656-662