

MODELING AND CONTROL OF A GRID CONNECTED PHOTOVOLTAIC SYSTEM USING MATLAB

Dayavanti Sisodia,
Mukesh Kumar Gupta
Associate prof. in EE Deptt.
Department of Electrical Engineering
Jagannath University Jaipur (Raj.)
sisodiadaya05@gmail.com

Abstract:-Grid-connected photovoltaic power systems are power systems energized by photovoltaic panels which are connected to the utility grid. Grid-connected photovoltaic power systems comprise of Photovoltaic panels, circle method of optimization techniques, solar inverters, power conditioning units and grid connection equipments. Stand-alone photovoltaic power systems these systems have batteries. When conditions are right, the grid-connected PV system supplies the excess power, beyond consumption by the connected load, to the utility grid.[1]

I Introduction

The model of the PV array proposed uses theoretical and empirical equations together with data provided by the manufacturer, solar radiation and cell temperature among others variables, in order to accurately predict the current-voltage curve. The PCS utilizes a two-stage energy conversion system topology that meets all the requirement of high quality electric power, flexibility and reliability imposed for applications of modern distributed energy resources (DER). [3],[5]

Residential grid-connected photovoltaic power systems which have a capacity less than 10 kilowatts can meet the load of most consumers. It can feed excess power to the grid, which in this case acts as a battery for

the system. The feedback is done through a meter to monitor power transferred. A typical case is when a consumer moves out of the house on vacation, the power produced by the panels will be much in excess of the demand. In this case, the excess power can yield revenue by selling it to the grid. The consumer only needs to pay the cost of electricity generated deducted from the cost of electricity consumed. Connection of the photovoltaic power system can be done only through an interconnection agreement between the consumer and the utility company. The agreement details the various safety standards to be followed during the connection.

2. Grid-Connected PV Systems

Grid-connected PV systems are the most popular solar electric system on the market today. Grid-connected systems are so named because they are connected directly to the electrical grid — the vast network of electric wires that spans the nation and crisscrosses your neighborhood. These systems are sometimes referred to as “battery-less grid-connected” or “battery-less utility-tied” systems. A grid connected system consists of five main components: (1) a PV array, (2) an inverter, (3) the main service panel or breaker box, (4) safety disconnects and (5) meters.

To understand how a battery-less grid-connected system works, let's begin with the PV array. The PV array produces DC electricity. It flows through wires to the inverter, which converts the DC electricity to AC electricity. The inverter doesn't just convert the DC electricity to AC; it converts it to grid-compatible AC — that is, 60 cycles per second, 120-volt (or 240-volt) electricity. Because the inverter produces electricity in sync with the grid, inverters in these systems are often referred to as “synchronous” inverters.

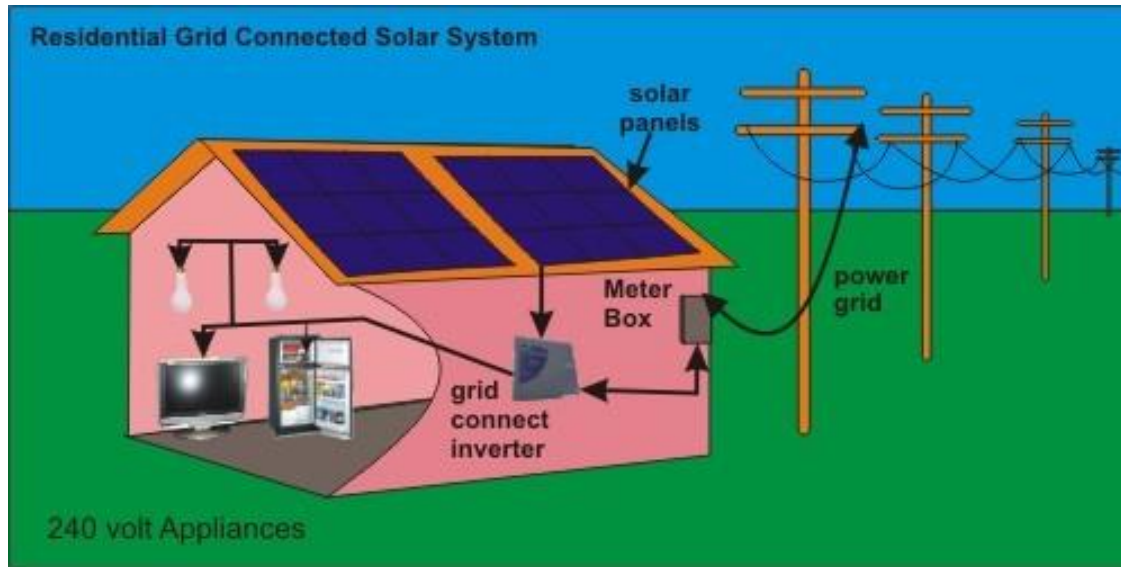

Figure I showing Grid connected solar system

The 120-volt or 240-volt AC produced by the inverter flows to the main service panel, aka the breaker box. From there, it flows to active loads (electrical devices that are operating). If the PV system is producing more electricity than is needed to meet these demands — which is often the case on sunny days — the excess automatically flows on to the grid. surplus electricity travels from the main service panel through the utility's electric meter, typically mounted on the outside of the house. It then flows through the wires that connect to the utility lines. From here, it travels along the power lines running by your home or business, where it is consumed in neighboring homes and businesses. After the electricity is fed to the grid, the utility treats it as if it were its own. End users pay the utility directly for the electricity you generate.[2]

3 PV Model

The equivalent circuit of a PV cell is shown in Fig. 2. It includes a current source, a diode, a series resistance and a shunt resistance

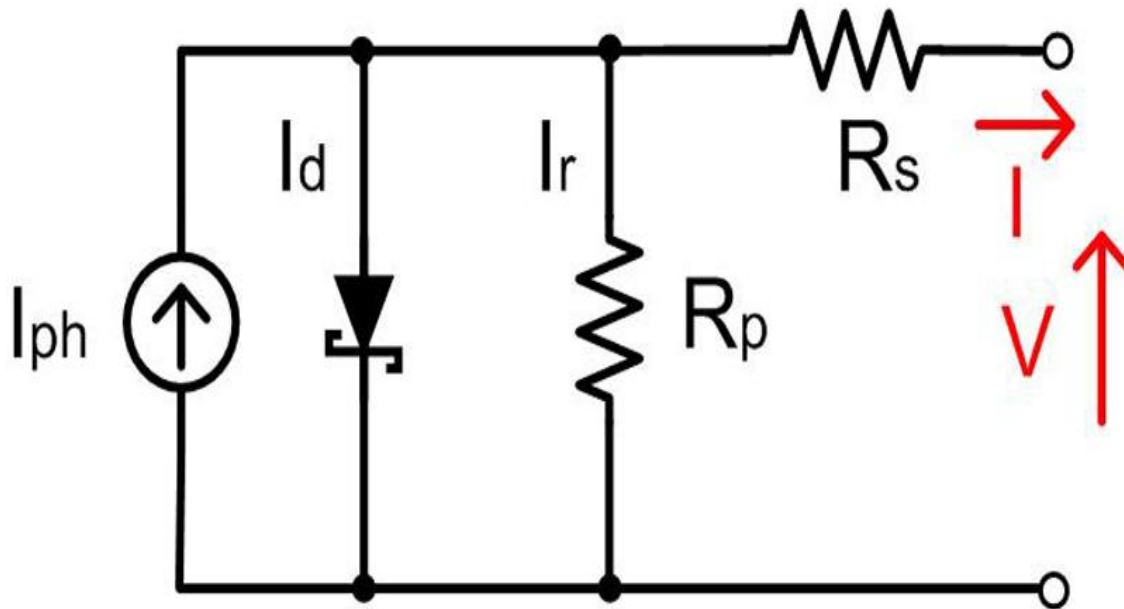
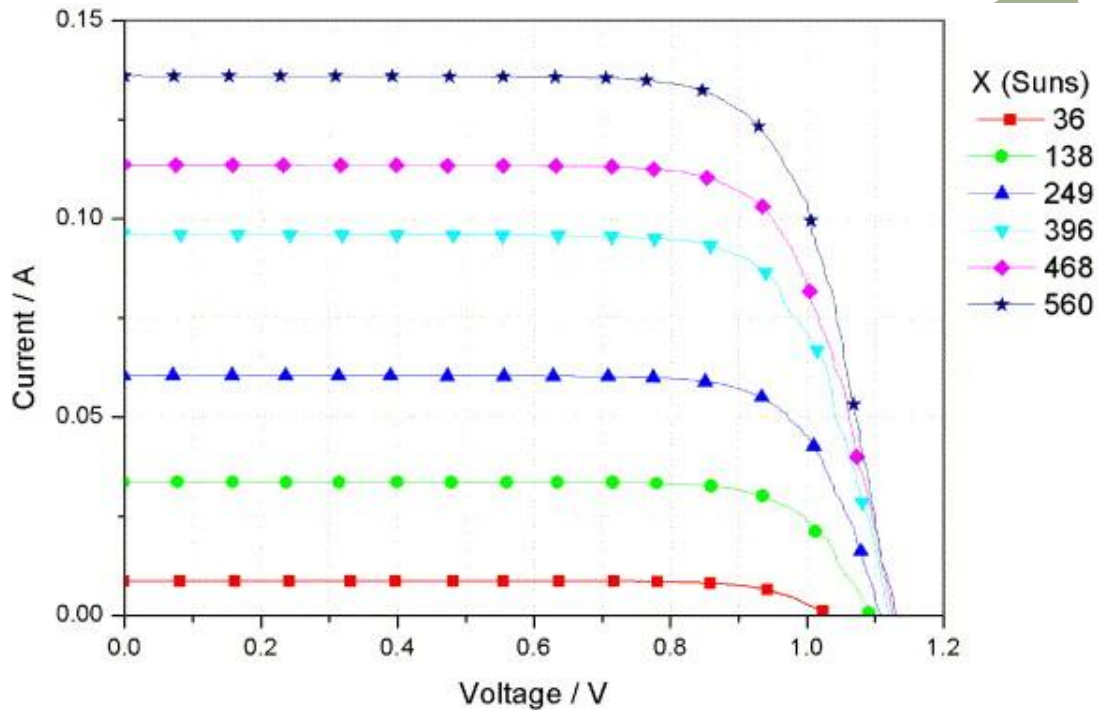

Fig 2 PV Model

Effects of Solar Radiation Variation The above model includes two subsystems: one that calculates the PV cell photocurrent which depends on the radiation and the temperature according to equation In most locations, an electric meter monitors the contribution of small-scale producers to the grid. The meter also keeps track of electricity the utility supplies to these homes or businesses when their PV systems aren't producing enough to meet their demands, or when the PV system is not operating (for example, at night)

In addition to the utility electric meter that monitors the flow of electricity to and from the local utility grid, grid-connected solar electric systems also contain two safety disconnects. Safety disconnects are manually operated switches that enable service personnel to disconnect key points in the system to prevent electrical shock when servicing the system. As shown in the schematic, the first disconnect is located between the solar array and the inverter. This is a DC disconnect. The manual disconnect allows the operator to terminate the flow of DC electricity from the array to the inverter in case the inverter needs to be serviced. These systems also require an AC disconnect switch. Shown in the schematic, this disconnect must be mounted outside the home or

business. It must be readily accessible to utility workers, and it must contain a switch that can be locked in the open position by utility workers so no electricity flows to or from the grid. This disconnect is required so workers can isolate PV systems from the electrical grid and work on electrical lines without fear of shock if, for example, a line in your area goes down in an ice storm.[4]



4. CONCLUSION

Matlab/SIMULINK model for the solar PV cell, modules and array was developed and presented in this paper. This model is based on the fundamental circuit equations of a solar PV cell taking into account the effects of physical and environmental parameters such as the solar radiation and cell temperature. The module model was simulated and validated experimentally using the high efficient PVL-124 solar laminate panel.

As a result of the study, one can benefit from this model as a photovoltaic generator in the framework of the Sim-Power-System

Matlab/SIMULINK toolbox in the field of solar PV power conversion systems. In addition, such a model would provide a tool to predict the behaviour of any solar PV cell, module and array under climate and physical parameters changes.

REFERENCES

1. Elhodeiby, a.s.; metwally, h.m.b; farahat, m.a (march 2011). "[performance analysis of 3.6 kw rooftop grid connected photovoltaic system in egypt](#)". international conference on energy systems and technologies (icest 2011): 151–157. retrieved 2011-07-21.
2. [Grid Connected Solar Electric - Photovoltaic \(PV\) Systems](#)"powernaturally.org. Retrieved 2011-07-21.
3. Martin, Denizar C.; de Souza, Kleber C. A. (2008). "[A Single-Phase Grid-Connected PV System With Active Power Filter](#)". INTERNATIONAL JOURNAL of CIRCUITS, SYSTEMS and SIGNAL PROCESSING 2 (1): 50–55. Retrieved 2011-07-21.
4. www.motherearthnews.com/renewable-energy/photovoltaic-systems-grid-connected-ze0z1202zhir.aspx
5. MATLAB/Simulink Based Modelling of Solar Photovoltaic Cell
Tarak Salmi Tarak Salmi et al., Vol.2, No.2, 2012