

Transmissibility Analysis of Magneto - Rheological Damper

Solepatil S.B.¹, Awadhani L.V.²

¹PG Student, Department of Mechanical Engineering, Pimpri Chinchwad College of Engineering Akurdi, Pune, India,

²Assistance Professor, Department of Mechanical Engineering, Pimpri Chinchwad College of Engineering Pune, India
sandeshpatil310@gmail.com

Abstract-Magneto-Rheological (MR) dampers are semi-active control devices that use MR fluids to produce controllable dampers. The advantage of MR dampers over conventional dampers are that they are simple in construction, compromise between high frequency isolation and natural frequency isolation, they offer semi-active control, use very little power, have very quick response, has few moving parts, have a relax tolerances and direct interfacing with electronics. Magneto-Rheological (MR) fluids are Controllable fluids belonging to the class of active materials that have the unique ability to change dynamic yield stress when acted upon by an magnetic field. This property can be utilized in MR damper where the damping force is changed by changing the rheological properties of the fluid magnetically. Semi-active control devices have received significant attention in recent years because they offer the adaptability of active control devices without requiring the associated large power sources. The critical parameter in this design is the gap distance between the piston and cylinder a prototype damper was designed, built, and tested for various blends of MR fluid with varying percentage 40% ,45% &50% (by weight of oil in damper) damper performance is observed and corresponding transmissibility of damper is plotted. Also Experimental Analysis of Max. Damping force was done for magnetic saturation limit.

Keywords: *Magnetorheological fluid, Magnetic circuit, Magnetic Saturation, Transmissibility.*

I. INTRODUCTION

A. Mr Damper:

Magneto rheological damper consists of a hydraulic cylinder, magnetic coils and MR fluid offering design simplicity. In addition to field controllability and design simplicity. MR dampers have many other advantages such as they require relatively very low power input, produce high yield stress up to 100 kPa, can be stably operated in a wide range of temperature (40-150°C) and MR fluids are not toxic and are insensitive to impurities [3]. Moreover, without the magnetic field the MR damper can work in a fail-safe mode, i.e. as a classical passive dashpot. Owing to these advantages, MR dampers have received much interest from different fields of applications including automotive suspensions, seismic vibration mitigation,

large bridges vibration control, knee prosthesis. [4]. Effective control of an MR damper mainly depends on understanding its nonlinear hysteretic behavior under an applied magnetic field.

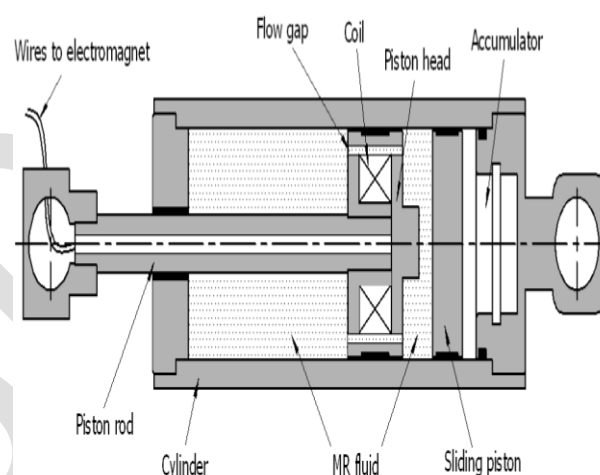

Fig.1.1 Magneto rheological Damper

B. Mr Fluid:

MR Fluids are non-colloidal suspensions of magnetisable particles that are of the order of 20-50 μm in diameter. MR devices are capable of much higher yield strengths when activated. The main difference between Ferro fluids and MR fluids is the size of the polarizable particles. In Ferro fluids, these particles are an order of magnitude smaller than MR Fluids that is they are 1-2 μm , in contrast to 20-50 μm for MR fluids. MR Fluid is composed of oil, usually mineral or silicon based, and varying percentages of ferrous particles MR Fluid displays Newtonian-like behavior when exposed to a magnetic field, the ferrous particles that are dispersed throughout the fluid form magnetic dipoles. These magnetic dipoles align themselves along lines of magnetic flux, as shown in Fig. On a larger scale, this reordering of ferrous dipole particles can be visualized as a very large number of microscopic beads that are threaded onto a very thin string as is shown in Fig. One can picture this thin string stretching from one magnetic

pole to the other and perpendicular to each paramagnetic pole surface.[2]

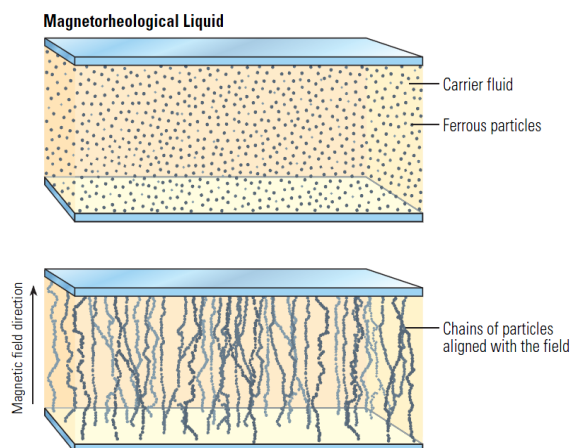

Fig 1.2 chain like structure formation in controlable fluid

These magnetic particles may be iron particles that can measure 3-10 microns in diameter. In addition to these particles it might also contain additives to keep the iron particles suspended. When this fluid is subject to a magnetic field the iron particles behave like dipoles and start aligning along the constant flux, shown in Fig.1.1(a). When the fluid is contained between the dipoles, its movement is restricted by the chain of the particles thus increasing its viscosity. Thus it changes its state from liquid to a viscoelastic solid.[2]

C. Mr. Fluid Composition:

MR-fluid formulation consists of three main components: magnetizable particles (with a volume fraction typically between 20% and 45%), a carrier fluid and an association of various additives. The proper selection and combination of these components is of prime importance since it will define all the macroscopic characteristics of the fluid such as its off-state viscosity, its maximum yield stress, its resistance to settling, its operating temperature range. This fact explains the abundance of literature on this topic and the wide variety of reported MR fluid formulations. In this section, we will summarize the main trends observed for MR-fluid composition.[2]

1). Magnetizable particles: Maximum inter-particle attraction (and thus maximum yield-stress) increases with the square of the saturation magnetization of the particles. The most widely used material for MR-fluid particles is carbonyl iron. Carbonyl iron powder is obtained by the thermal decomposition of iron pentacarbonyl $\text{Fe}(\text{CO})_5$, leading to highly spherical particles in the 1-10 μm range. The spherical shape is of particular interest since it makes the particles less abrasive, more robust and durable. These particles are further characterized by an onion skin structure and an iron content up to 97.8% (Figure 1.3). Iron powders obtained from less expensive processing techniques

(such as water atomization) have also been considered and used in MR-fluid formulations. However, it should be noticed that these particles exhibit much larger sizes (10-100 μm) and are more irregular in shape. Furthermore, highly irregular particles lead to higher fluid viscosity compared to spherical particles at the same volume fraction. [2]

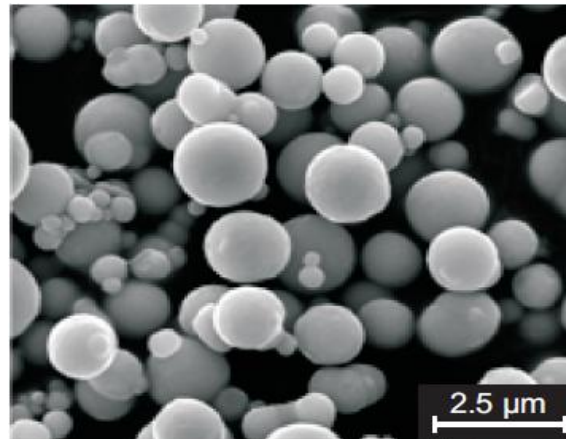

Fig 1.3 Magnetizable particles in spherical shape

2). Carrier fluid: Carrier fluids are selected based on their intrinsic viscosity, their temperature stability and their compatibility with other materials of the device. The most common carrier fluids are hydrocarbon oils, which can either be mineral oils or synthetic oils (or a combination of both), good lubrication, durability and the availability of a large range of additives. Silicon oils can be used instead in order to achieve a broader operating temperature range or due to compatibility issues with other materials of the device (e.g. rubber seals). gives guidelines regarding the temperature range of some MR-fluid formulations as well as their compatibility with typical seals materials.

3). Additives: Many types of additives, often proprietary, are used in MR-fluid formulations. They have many purposes such as: inhibit particle settling and agglomeration, reduce friction, prevent particle oxidation and wear. The major impact of these properties on the MR-fluid stability and durability, which are crucial in industrial applications, explains the fact that, in recent years, much of the MR-fluid research effort was focused on the development of new additive packages. Particle settling may appear in MR-fluids due to the large difference between particles and carrier fluid densities. This phenomenon may be accompanied by particle agglomeration, which means that particles are sticking together in the absence of magnetic field. While a small level of particle settling is not really an issue in devices where the fluid is naturally and efficiently remixed during operation.

II. OPERATIONAL PRINCIPLE

MR fluid damper is a device to give damping by the shear stress of MR fluid. A MR damper has the property

whose damping changes quickly in response to an external magnetic field strength. The MR fluid is filled in the working gap between the fixed outer cylinder and inner cylinder. The inner cylinder moves at a speed V . In the absence of an applied magnetic field, the suspended particles of the MR fluid cannot restrict the relative motion between the fixed outer cylinder and inner cylinder.

However, in the course of operation, the magnetic flux path is formed when the electric current puts through the solenoidal coil. As a result, the particles are gathered to form the chain-like structures, with the direction of the magnetic flux path. These chain-like structures restrict the motion of the MR fluid, thereby increasing the shear stress of the fluid. The damper can be achieved by utilizing the shear force of MR fluid. The damping values can be adjusted continuously by changing the external magnetic field strength.

III. MAGNETIC CIRCUIT DESIGN

Magnetic circuit of MR Damper consist of Upper piston part, lower piston part & casing. Magnetic coil of required turns were wounded between this part. When a magnetic field (H) is applied for the first time to such material, the magnetic induction (B) within the material increases slowly at first, then more rapidly, then very slowly again and finally reaches called Magnetic saturation. Magnetic potential F can be calculated by Magnetic reluctance R_m and Magnetic flux Φ . [1]

$$F = R_m \cdot \Phi \dots \dots \dots (1)$$

Also, $F = NI$

Whereas N is no. of turns and I is Max. current.

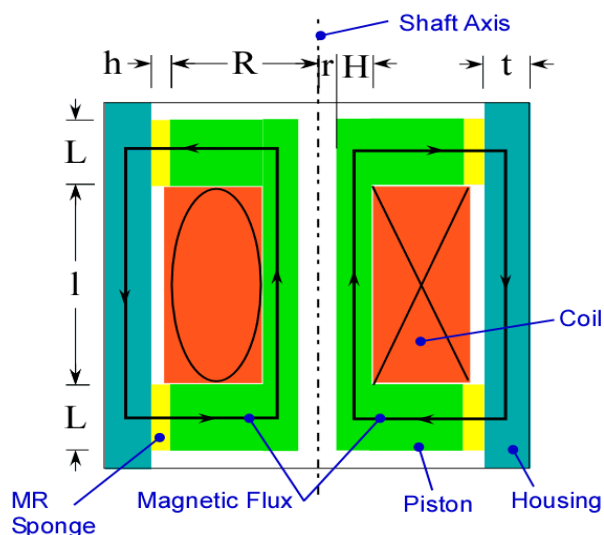

Fig.3.1 Dimensions of MR Fluid Damper

Total reluctance of the device is given by.

$$R_T = \sum_{i=1}^n \frac{L_i}{\mu_i A_i}$$

Whereas L_i , A_i , and μ_i are the length, cross sectional area, and permeability of element i in the magnetic flux path. The magnetic flux Φ and magnetic flux density B are given by [1]

Sample 2: In this sample 35% iron magnetic particles and 65% fork oil was used.

Sample 3: In this sample 40% iron magnetic particles and 60% fork oil was used.

Sample 4: In this sample we take 45% iron magnetic particles and 55% fork oil was used.

$$\Phi = NI/RT \text{ in weber} \dots \dots \dots (2)$$

$$B = \Phi/A \text{ in Tesla} \dots \dots \dots (3)$$

Magnetic Force developed by circuit,

$$F = \tau A \dots \dots \dots (4)$$

Whereas τ is shear stress Value of MR fluid 45-100Kpa and A is magnetic flow area.

IV. EXPERIMENTAL SETUP

The designed damper was tested to checked its performance by using Shock absorber test rig. Eccentric mass was used to produce Vibrational Force. If we increased the speed of motor the vibrational force got increased. Rotary motion of mass converted into linear motion. Damper was tested for various speed and current supplied also varied from 0 to 2A. Transmitted load was measured by using load cell indicator.

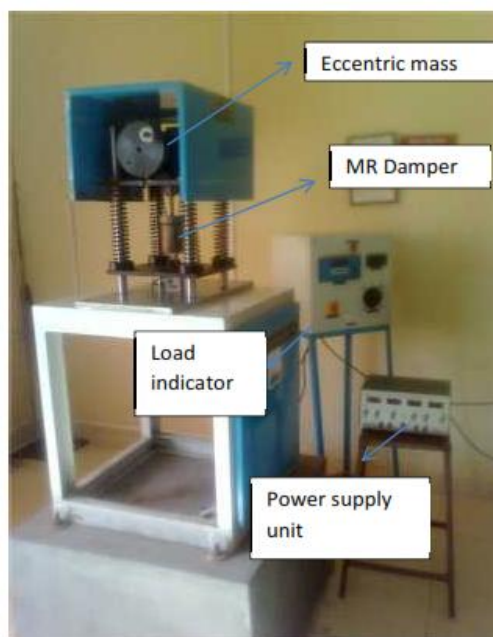

Fig. 4.1 MR Damper test rig.

The following blending Mixture was used for experiment:

Sample 1: In this sample 40% iron magnetic particles and 60% Siliconoil was used.

Sample 2: In this sample 45% iron magnetic particles and 55% Silicon oil was used.

Sample 3: In this sample we take 50% iron magnetic particles and 50% Silicon oil was used.

V. RESULT AND DISCUSSION

Magnetorheological Damper gives different response for increased Magnetic field. Transmissibility of Damper for various blending Mixture is presented in following tables:

SAMPLE 1(40% Iron particle): Transmissibility of damper

Current(Amp)	0.1	0.2	0.3	0.4	0.5	0.6	0.7	0.8
Speed(rpm)								
150	1.82	1.73	1.64	1.52	1.28	1.28	1.1	0.83
200	2.38	2.21	1.92	1.92	1.61	1.52	1.28	1.16
300	1.78	1.54	1.32	1.28	1.22	0.92	0.92	0.92

SAMPLE 2 (45% Iron particle): Transmissibility of damper .

CURRENT(Amp)	0.1	0.2	0.3	0.4	0.5	0.6	0.7	0.8
Speed(RPM)								
150	1.84	1.76	1.52	1.52	1.12	0.91	0.78	0.78
200	2.29	2.16	1.82	1.82	1.74	1.18	1.12	1.12
300	1.74	1.46	1.34	1.26	1.19	0.92	0.84	0.84

SAMPLE 3 (50% iron particle): Transmissibility of damper

CURRENT(Amp)	0.1	0.2	0.3	0.4	0.5	0.6	0.7	0.8
Speed(RPM)								
150	1.86	1.78	1.45	1.277	1.225	0.81	0.775	0.623
200	2.36	2.23	2.2	1.77	1.72	1.05	0.775	0.747
300	1.75	1.55	1.375	1.275	1.15	1.02	0.8	0.727

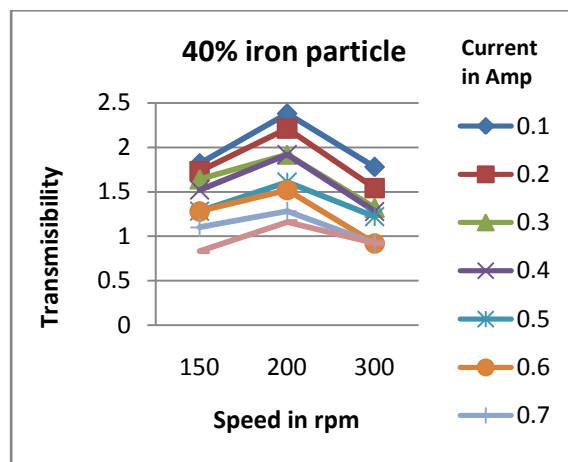

Graph 8.1 Transmissibility v/s speed for sample1

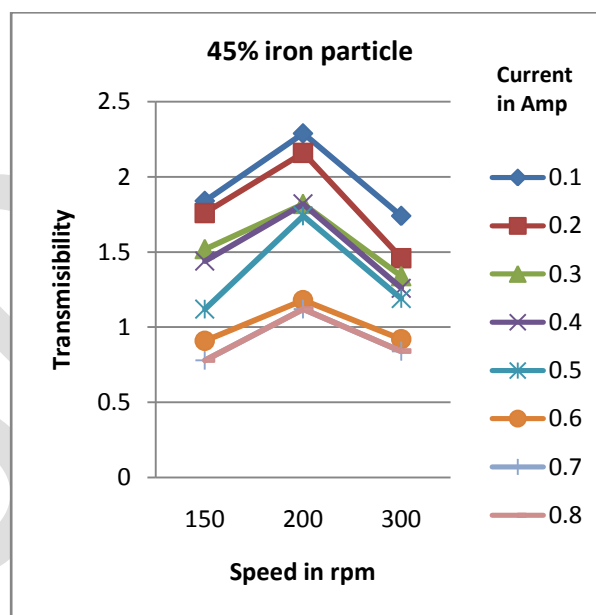

Graph 8.2 Transmissibility v/s speed for sample 2

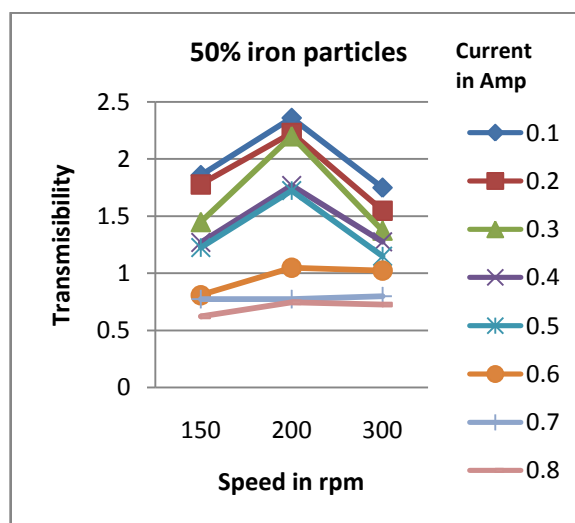

Graph 8.3 Transmissibility v/s speed for sample 3

1. Transmissibility of damper was decreased with increasing current up to resonance for different Blending Mixture. Reduction in transmissibility is from 2.362 to 0.727.
2. Transmissibility of damper before resonance (200rpm) and after resonance is less compared to transmissibility of damper at resonance. Transmissibility value for 50% blending mixture was higher than other Mixture.
3. Magnetic field can Sustain Max. Damping force for 0.4A after that Magnetic saturation Decreasing the damping effect.
4. Due to resolution low at 0.8A current and 300 rpm transmitted force shown by graph is Reduce but in actual damper transmit force which has low value.

CONCLUSION:

1] The transmissibility of damper at resonance for blend number 3 (50% iron particle by weight) is less (0.76) at 0.8 amp. Highest Transmissibility reduction occurs from 2.36 to .7275 at MR fluid with 50% of iron particles (20 μm size) is suggested for MR Damper.

2] The transmissibility of damper when no current supplied to the coil is high. The transmissibility of damper goes on decreasing as we increase the amount of current supplied to coil of damper up to damper magnetic saturation limit.

REFERENCES

- [1] HonghuiZhang ,Changrong Liao , Weimin Chen, Shanglian Huang,Center for Intelligent Structures of Chongqing University, Chongqing, P.R.C, 400044A magnetic design method of mr fluid dampers and fem analysis on magnetic saturation. Sept (2003).
- [2] FarzadAhmadkhanlou, M.S. The Ohio state University (2008).Design, modeling and control of magnetorheological fluid-based force feedback dampers for telerobotic systems. (2008).
- [3] A.Ashfak, A. SaheedK.K ; Design, Fabrication and Evaluation of MR Damper. Int.journal of Aerospace and mechanical Engineering ,5th January 2011. 27-31
- [4] JacekMatesuzBajkowski. Design, Analysis and performance evaluation of the linear, Magnetorheological damper'.Actamechanica automatica vol.6, January 2012, 5-9.