

Application of Dual Tone Multi Frequency Technology and Sensing in Autonomous Robotic Navigation

Jaspreet Kaur

M.Tech Student, Digital Communication, CGI Bharatpur, RTU Kota, Rajasthan, India

Abstract - This paper advocates the operation of a toy car that is controlled by a mobile phone that makes a call to the mobile phone attached to the car. In the course of a call, if any button is pressed, a tone corresponding to the button pressed is heard at the other end of the call. This tone is called DTMF (dual-tone-multiple-frequency). The car perceives this DTMF tone with the help of the phone stacked in the car. The received tone is processed by the (ATmega16) microcontroller with the help of DTMF decoder MT8870. The decoder decodes the DTMF tone into its equivalent binary digit and this binary number is sent to the microcontroller. The microcontroller is programmed to take a decision for any given input and outputs its decision to motor drivers in order to drive the motors in forward direction or backward direction or left and right direction. The mobile phone that makes a call to mobile phone stacked in the car act as a remote. For that reason this paper does not require the construction of receiver and transmitter units.

Keywords- DTMF Decoder (MT8870 series), motor driver (L293D), Microcontroller, Cell Phones, Dumb Car

I. INTRODUCTION

Dual-tone multi-frequency (DTMF) signaling is used for telecommunication signaling over analog telephone lines in the voice-frequency band between telephone handsets and other communications devices and the switching center [1]. The version of DTMF used for telephone tone dialing is known by the trademarked term Touch-Tone (cancelled March 13, 1984), and is standardized by ITU-T Recommendation Q.23. It is also known in the UK as MF4 [2]. Other multi-frequency systems are used for signaling internal to the telephone networks a method of in-band signaling. DTMF tones were also used by cable television broadcasters to indicate the start and stop times of local commercial insertion points during station breaks for the benefit of cable companies.

Until better out-of-band signaling equipment was developed in the 1990s, fast, unacknowledged, and loud DTMF tone sequences could be heard during the commercial breaks of cable channels in the United States and elsewhere [3]. The conventional wireless controlled toy car user circuits have drawbacks of limited working range, limited frequency range and limited control. However, these limitations can be overcome by using the mobile phone technologies in this purpose. It provides the advantages to control, working range as large as the coverage area of the service provider, no interference

with other controllers and up to twelve controls [4].

II. LITERATURE REVIEW

This propeller-driven radio controlled boat, built by Nikola Tesla in 1898, is the original prototype of all modern-day uninhabited aerial vehicles and precision guided weapons. In fact, it is among all remotely operated vehicles in air, land or sea [5]. Powered by lead-acid batteries and an electric drive motor, the vessel was designed to be maneuvered alongside a target using instructions received from a wireless remote-control transmitter. Once in position, a command would be sent to detonate an explosive charge contained within the boat's forward compartment. The weapon's guidance system incorporated a secure communications link between the pilot's controller and the surface-running torpedo in an effort to assure that control could be maintained even in the presence of electronic counter measures [6]. During World War II in the European Theatre the U.S. Air Force with three basic forms radio-control guided weapons. In each case, the weapon would be directed to its target by a crew member on a control plane. The first weapon was essentially a standard bomb fitted with steering controls. The next evolution involved the fitting of a bomb to a glider airframe, one version, the GB-4 having a TV camera to assist the controller with targeting. The third class of guided weapon was the remote controlled B-17. It's known that Germany deployed a number of more advanced guided strike weapons that saw combat before either the V-1 or V-2. They were the radio-controlled Herschel's Hs293A and Ruhrstahl's SD1400X, known as "FritzX," both air-launched, primarily against ships at sea [5].

DTMF is the most common telecommunications signaling method used in Australia. DTMF stands for Dual Tone Multiple Frequency; it is used to send information through phone lines to and from local exchange. Dual Tone Multiple Frequency (DTMF) is also known as Touch-tone, Tone Dialing, VF Signaling and MF Dialing [7]. Each DTMF tone consists of two simultaneous tones (one from the high group and one from the low group), which are used to indicate which number or symbol that is pressed on the telephone's keypad. For example if number 5 is pressed in telephone's keypad, the tones that will hear are 1336 Hz and 770 Hz played simultaneously. DTMF was designed so that it is possible to use acoustic transfer. The DTMF tones can be sent from a standard speaker and be received using a standard microphone (providing it is

connected to a decoding circuit of some type). DTMF tones are simply two frequencies played simultaneously by a standard home phone/fax or mobile phone. Each key on your telephone's keypad has a unique frequency assigned to it. When any key is pressed on your telephone's keypad the circuit plays the corresponding DTMF tone and sends it to your local exchange for processing. DTMF tones can be imitated by using a White Box or Tone Dialer. It is also possible to record DTMF tones using a tape recorder or computer microphone and then played into the mouthpiece of your telephone to dial numbers. However if there is a significant amount of background sound behind the recorded DTMF tones, the tones may not work. Dual Tone Multiple Frequency is the basis of voice communications control. Modern telephone circuits use DTMF to dial numbers, configure telephone exchanges (switchboards) from remote locations, program certain equipment and so on. Almost any mobile phone is capable of generating DTMF, providing a connection has already been established. This is for the use of phone banking; voicemail services and other DTMF controlled applications. DTMF was designed so that it is possible to use acoustic transfer. The DTMF tones can be sent from a standard speaker and be received using a standard microphone (providing it is connected to a decoding circuit of some type). DTMF tones are simply two frequencies played simultaneously by a standard home phone/fax or mobile phone. Each key on your telephone's keypad has a unique frequency assigned to it. When any key is pressed on your telephone's keypad the circuit plays the corresponding DTMF tone and sends it to your local exchange for processing. DTMF tones can be imitated by using a White Box or Tone Dialer. It is also possible to record DTMF tones using a tape recorder or computer microphone and then played into the mouthpiece of your telephone to dial numbers. However if there is a significant amount of background sound behind the recorded DTMF tones, the tones may not work properly and cause problems when trying to dial numbers.

Below is a Dual Tone Multi Frequency (DTMF) map for a 4X4-matrix keypad, the map shows each unique frequency which is assigned to each key on a standard 4X4 telephone keypad. The frequencies are exactly the same for a 3X4 matrix keypad without the keys A, B, C and D.

	1209Hz	1336Hz	1477Hz	1633Hz
697Hz	1	2 ABC	3 DEF	A
770Hz	4 GHI	5 JKL	6 MNO	B
852Hz	7 PQRS	8 TUV	9 WXYZ	C
941Hz	*	0	#	D

Fig-1: Dual Tone Multi Frequency (DTMF) map.

However, this is not a standard keypad. This keypad has 4 more keys than a standard keypad (3X4-matrix). The keys A, B, C and D are not commonly used on standard home phone/fax, office phone or payphone. Each of the keys A, B, C and D are system tones/codes and are mainly used to configure telephone exchanges or to perform other special functions at an exchange. For example, the corresponding tone/code assigned to the A key is used on some networks to move through various carriers (this function is prohibited by most carriers).

Filter is one of the very important devices of this DTMF technology. When DTMF was created individual and unique frequencies were chosen so that it would be quite easy to design frequency filters and so that the tones could easily pass through telephone lines (the maximum guaranteed bandwidth for a standard telephone line extends from around 300 Hz to 3.5 kHz). DTMF was not intended for data transfer; it was designed for control signals only. With a standard DTMF encoder/decoder, it is possible to signal at a rate of around 10 tones/signals per second. A standard DTMF tone should always be played for at least 50ms with a further 50ms space duration for maximum reliability. The contemporary mobile keypad is laid out in a 3x4 grid, although the original DTMF keypad had an additional column for four menu selector keys. When used to dial a telephone number, pressing a single key will produce a pitch consisting of two simultaneous pure tone sinusoidal frequencies. The row in which the key appears determines the frequency, and the column determines the high frequency. For example, pressing the key will result in a sound composed of both 697 Hz and 1209 Hz tone [8, 15]. The original keypads had levers inside, so each button activated two contacts. The multiple tones are the reason for calling the system multi frequency.. These tones are then decoded by the switching center to determine which key was pressed.



Fig-2: A Dtmf Mobile Key

III. CIRCUIT DESIGN

The important components of this car are DTMF decoder, microcontroller and motor driver. An MT8870 series DTMF decoder is used here. All types of the MT8870

series use digital counting techniques to detect and decode all the 16 DTMF tone pairs into a 4-bit code output. The built-in dial tone rejection circuit eliminates the need of pre-filtering. When the input signal given at pin 2(IN-) in single-ended input configuration is recognized to be effective, the correct 4-bit decode signal of the DTMF tone is transferred to (pin11) through (pin14) outputs. The pin11 to pin14 of DTMF decoder are connected to the pins of microcontroller (pa0 to pa3). The ATmega16 is a low power, 8-bit CMOS microcontroller based on the AVR enhanced RISC architecture. It provides the following features: 16kb of in-system programmable flash program memory with read-while-write capabilities, 512 bytes of EEPROM, 1kb SRAM, and 32 (I/O) lines. Outputs from port pins PD0 through PD3 and PD7 of the microcontroller are fed to the inputs IN1 through IN4 and enable pins (EN1 and EN2) of motor driver L293D IC, respectively to drive two geared dc motors. Switch S1 is used for manual reset. The microcontroller output is not sufficient to drive the dc motors, so Current drivers are required for motor rotation. The L293D is a quad, high-current, half-h driver designed to provide bidirectional drive currents of up to 600mA at voltages from 4.5V to 36V. It makes it easier to drive the dc motors. The L293D consists of four drivers. Pins IN1 through IN4 and OUT1 through OUT4 are the input and output pins respectively, of driver 1 through driver 4. Drivers 1 and 2, and driver 3 and 4 are enabled by enable pin 1(EN1) and pin 9 (EN2), respectively. When enable input EN1 (pin1) is high, drivers 1 and 2 are enabled and the outputs corresponding to their inputs are active. Similarly, enable input EN2 (pin9) enables drivers 3. The complete circuit diagram is illustrated in figure-3 below.

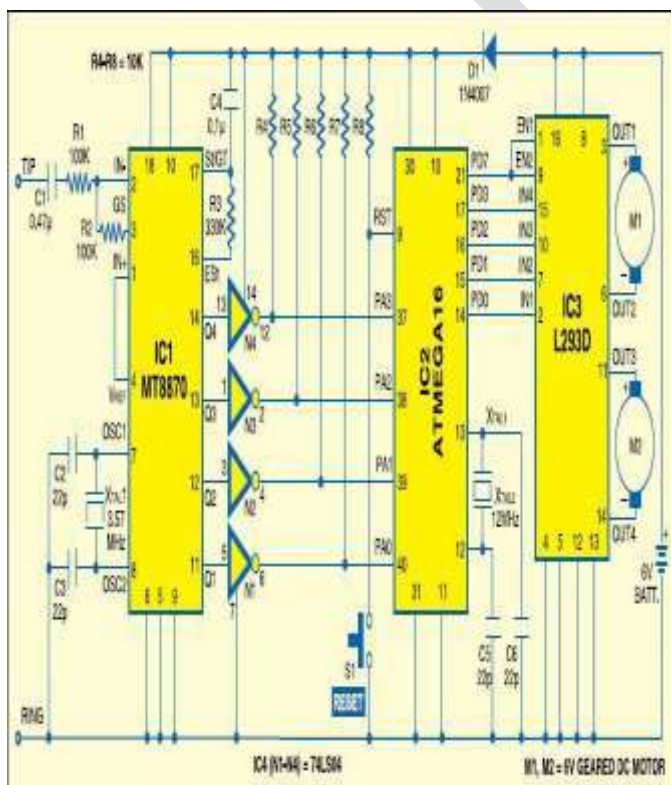

Fig.-3 Circuit Diagram

In order to control the toy car, a call need to make to the cell phone attached to the toy car (through headphone) from any phone, which sends DTMF tones on pressing the numeric buttons. The cell phone in the car kept in 'auto answer' mode. So after a ring, the cell phone accepts the call. Now particular button may press on the mobile phone for pre defined desired action. The DTMF tones thus produced are received by the cell phone in the car. These tones are fed to the circuit by headset of the cell phone. The MT8870 decodes the received tone and sends the equivalent binary number to the microcontroller. According to the program in the microcontroller, the car starts moving. When the number key '2' (binary equivalent 00000010) is pressed on the mobile phone.

The microcontroller outputs '10001001' binary equivalent. Port pins PD0, PD3 and PD7 are high. The high output at PD7 of the microcontroller drives the motor driver (L293D). Port pins PD0 and PD3 drive motors M1 and M2 in forward direction (as per table). Similarly, stop condition as per the condition. Details conditions are shown in the flow chart diagram.

The primary objective of this project was to build a cell phone link between a transmitter and a dumb car and provide the capability to operate the car from a remote location. The purpose of using the cell phone was to make the operation possible from any remote location in the world where cell phone use is available. The product would include two interface systems. One interface would operate between the transmitter and a sending cell phone, and a second interface would operate between the receiving cell phone and the dumb car. The interface on the sending side would allow production and encoding of signals suitable for transmission via a cell phone. The interface on the receiving end would process the signals received by the cell phone and control the dumb car. The simple diagram below illustrates the concept of the project.

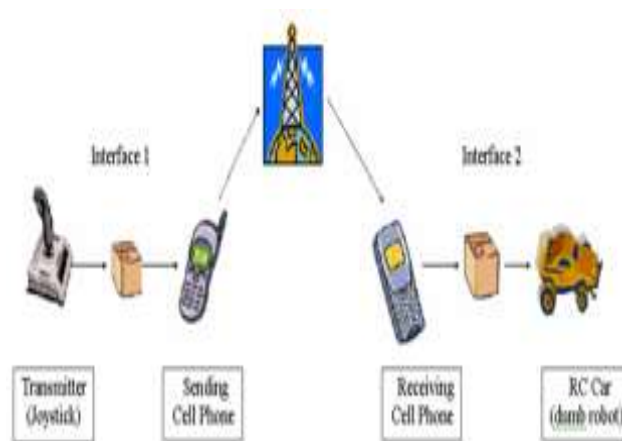

Fig-4: Pictorial representation of the complete system



Fig-5: Practical Implementation of the system.

In order to the work properly this system, certain specifications are made. They are:

- The system must have an interface between the transmitter, the sending phone and another interface between the receiver phone and the robot.
- The cell phones should be any common cell phone. However, a specific model can be chosen because of hands free set connection type.
- Very negligible delay compare to the operation of the off-the-shelf unit one.
- The system should be a low power device.
- Both mobile phones should have activated DTMF service for controlling the robot from a remote location.

The working procedure for this model is very simple. At first, the robot needs to turn ON by giving power supply of 10v battery. Now dial a mobile number that is connected with robot at remote location. Then after ringing the remote mobile connected with robot, it will automatically connected by Auto-Answer option in mobile phone just like an internet connection established between two systems. It needs to be ensured that DTMF tones sending facility should be active between both mobiles. After connection establishment the keyboard need to use to operate the robot car in particular direction.

There are 3 main parts of this system. They are the decoder, microcontroller and the motor driver. The following paragraph explains about their working procedure in briefly. The MT-8870 DTMF DECODER IC is a full DTMF Receiver that integrates both band split filter and decoder functions into a single 18-pin DIP or SOIC package. Manufactured using CMOS process technology, the M-8870 offers low power consumption (35mW max) and precise data handling. Its filter section uses switched capacitor technology for both the high and low group filters and for dial tone rejection. Its decoder

uses digital counting techniques to detect and decode all 16 DTMF tone pairs into a 4-bit code. External component count is minimized by provision of an on-chip differential input amplifier, clock generator and latched tri-state interface bus. Minimal external components required include a low-cost 3.579545MHz color burst crystal, a timing resistor, and a timing capacitor. The M-8870-02 provides a "power-down" option which, when enabled, drops consumption to less than 0.5mW [10]. The M-8870-02 can also inhibit the decoding of fourth column digits. M-8870 operating functions include a band split filter that separates the high and low tones of the received pair and a digital decoder that verifies both the frequency and duration of the received tones before passing the resulting 4-bit code to the output bus [12].

The low and high group tones are separated by applying the dual-tone signal to the inputs of two 6th order switched capacitor band pass filters with bandwidths. That corresponds to the bands enclosing the low and high group tones. The filter also incorporates notches at 350 and 440 Hz, providing excellent dial tone rejection. Each filter output is followed by a single-order switched capacitor section that smoothes the signals prior to limiting. Signal limiting is performed by high gain comparators provided with hysteresis to prevent detection of unwanted low-level signals and noise. The comparator outputs provide full-rail logic swings at the frequencies of the incoming tones. Decoder the M-8870 uses a digital counting technique to determine the frequencies of the limited tones and to verify that they correspond to standard DTMF frequencies [11]. A complex averaging algorithm is used to protect against tone simulation by extraneous signals (such as voice) while tolerating small frequency variations. The algorithm ensures an optimum combination of immunity to talk off and tolerance to interfering signals (Third tones) and noise. When the detector recognizes the simultaneous presence of two valid tones (known as signal condition), it raises the Early Steering flag (Est.) [12]. Any subsequent loss of signal condition will cause Est. to fall.

As the microcontroller used in this system is a very popular one hence the details about this microcontroller is show explained here. However, information about the ATMEGA 16 microcontroller can be found on [13,16].

The L293D IC (Motor Driver) Device is a monolithic integrated high voltage, high current four channel driver designed to accept standard DTL or TTL logic levels and drive inductive loads (such as relays solenoids, DC and stepping motors) and switching power transistors [14]. To simplify use as two bridges each pair of channels is equipped with an enable input. A separate supply input is provided for the logic, allowing operation at a lower voltage and internal clamp diodes are included. This device is suitable for use in switching application at frequencies up to 5 kHz. The L293D is assembled in a 16 lead plastic Package which has 4 center pins connected together and used for heat sinking. The L293DD is

assembled in a 20 lead surface Mount which has 8 centre pins connected together and used for heat sinking. A circuit connection of the motor driver is shown

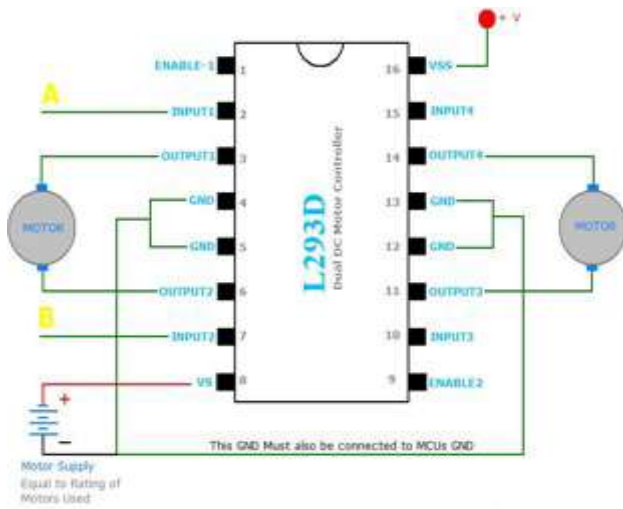

Fig-7: Circuit Configuration of L293D.

IV. APPLICATION

- It can also be used to make mobile bomb by making some modification.
- If we use the switching IC instead of the driver IC we can turn on and off any appliances connected to this toy car.
- This toy car can carry in their capacity.
- This can be fitted in an attractive form of a toy car for child pleaser.
- Adding a camera could highly increase its popularity.
- Password protected systems have used in many wars and so on.

V. CONCLUSION

In this project, the toy car is controlled by a mobile phone that makes a call to the mobile phone attached to the car. In the course of a call, if any button is pressed, a tone corresponding to the button pressed is heard at the other end of the call. This is a wireless controller toy car hence the limitation of wired is completely overcome by using latest technology of mobile phones. However, there are still lots of scopes to improve the stability and ability of this system. The mobile phone that makes a call to mobile phone stacked in the car act as a remote. Hence this project does not require the construction of receiver and transmitter units. It is undoubtedly true that, this model can be a very significant device in case of the information acquisition from the remote areas where direct interference of human being is quite impossible hence it would be a very crucial topic to do further research on it.

APPENDIX

The programming codes for this model are done in the programming language C and are given below.

```

void main(void)
{
    unsigned int k, h;
    DDRC=0x00;
    DDRD=0xFF;
    while (1)
    {
        k =~PINC;
        h=k & 0x0F;
        switch (h)
        {
            case 0x02: //if I/P is 0x02
            {
                //O/P 0x89 ie Forward
                PORTD2_bit = 1;
                PORTD3_bit = 0;
                PORTD7_bit = 1;
                break;
            }
            case 0x08: //if I/P is 0x08
            {
                //O/P 0x86 ie Backward
                PORTD2_bit = 0;
                PORTD3_bit = 1;
                PORTD7_bit = 1;
                break;
            }
            case 0x04:
            {
                // Left turn
                PORTD0_bit = 1;

```

```

PORTD1_bit = 0;

PORTD7_bit = 1; break;
}

case 0x06:
{
// Right turn

PORTD0_bit = 0;

PORTD1_bit = 1;

PORTD7_bit = 1;

break;
}

case 0x05:
{
PORTD=0x00; // Stop

break;
}
}
}
}
}
}
}
}

```

- [12] "DTMF Tester", Electronics For You' Magazine, Online Edition (June 2010).
- [13] Introduction to the Atmel ATmega16 Microcontroller, San José State University Dept. of Mechanical and Aerospace Engineering, 6th. September, 2010.
- [14] J. Banuchandar, V. Kaliraj, P. Balasubramanian, S. Deepa, N. Thamilarasi, Automated Unmanned Railway Level Crossing System, International Journal of Modern Engineering Research (IJMER), Vol.2, Issue.1, Jan-Feb 2012 pp-458-463 ISSN: 2249-6645.
- [15] Edwin Wise, Robotics Demystified (Mc-Graw Hill, 2005)
- [16] K. J. Ayala, 8051 Microcontroller (Delmar Learning, Thomson, 3rd Edition).

BIOGRAPHY

JASPREET Kaur is a final year student of M.Tech, Digital Communication from CGI, Bharatpur, RTU, Kota, Rajasthan, India . She has completed her bachelor Degree in Electronics & Telecommunication engineering from IETE, New Delhi.

REFERENCES

- [1] Awab Fakh, Jovita Serrao, Cell Phone Operated Robotic Car. International Journal of Scientific & Engineering Research, ISSN 2229-5518.
- [2] L. Schenker, "Pushbutton Calling with a Two- Group Voice-Frequency Code", The Bell System Technical Journal, 39(1), 1960, 235-255, ISSN 0005-8580
- [3] Siegmund M. Redl, Matthias K. Weber, Malcolm W. Oilphant, GSM and Personal Communications Handbook, Artech House Boston, London.
- [4] V. Subramanyam, Electric Drives (Mc-Graw Hill, 1996)
- [5] Information available at the following link, <http://www.tfcbooks.com/special/missiles.htm>
- [6] Leland Anderson, Nikola Tesla —Guided Weapons & Computer Technology', Tesla Presents Series Part 3.
- [7] Analog Telephony Compliance Requirements Overview, Hermon Laboratories TILtd. 2009.
- [8] Hector of SCP, Dual Tone Multiple Frequency A guide to understanding and exploiting Australians most common telecommunications signaling method. December 10th 2003
- [9] S. A. Nasar, I. Boldea, Electric Drives (CRC/Taylor and Francis, 2006)
- [10] M-8870 DTMF Receiver, Information available at the following link, www.datasheetcatalog.org/datasheet/clare/M-8870-01SMTR.pdf
- [11] Milove H. Kothari, Telephonic Control Of Electrical Equipment. Electrical Engineering From L.D. College Of Engineering.