

# Design and Development of a Low Cost Smart Electronic School Bell

**Kazi Wohiduzzaman, Rahmot Ullah, Ashit Sharkar**

*Department of Electrical and Electronic Engineering, Metropolitan University, Bangladesh*

DOI : <https://doi.org/10.51583/IJLTEMAS.2024.130913>

Received: 18 September 2024; Accepted: 24 September 2024; Published: 10 October 2024

**Abstract:** A considerable advancement of automation over the decades shows automation is very much essential in every sectors especially where time is a major factor. Hence there is a huge demand for automated notification or bell system which has high degree of accuracy and low cost. The main purpose of this project is to develop a smart bell system which can be used all kinds of educational institutions. Smart school bell implement a smart way to manage class periods and breaks without use of manually operated manpower. There is a controller machine, where each class can be set up as desired and from this machine one speaker will be installed in each class. Bell will play in every room through the speakers. The machine will be equipped with a microphone that allows the headmaster or anyone to send the message to all classes simultaneously or to any class separately. The system is made by establishing a serial interface between PIC microcontroller (PIC16F877A) and a Real Time Clock (RTC) is designed with the help of PIC 16F72 module and the LCD display units provide real time and class time separately. The software coding part is done using micro C and hardware implementation is done using the components. The main advantage of this project is due to very easy circuit operation it is easy to operate, cost effective and can be password protected to avoid unauthorized access.

**Keywords:** Smart, Bell, LED, LCD, Microcontroller, Relay, Automatic, Time Display, RTC, PIC, and Switch.

## I. Introduction

Now days, we are living in the automation world, where everything is getting automated with the help of an advanced programmable controller. Smart School bell system is such kind of automation for schools or an institution that reduces the effort necessary to control an electric bell manually that gives alarm for certain intervals of time based on school or college timings. The proposed system uses a simple pic microcontroller to make the product affordable. Generally conservative methods need a peon or bell operator to control the bell system for every class and intermission in schools and also institutions. Such systems require considerable human efforts to do so and need progress in order to become automatic electronic bell that reduce human efforts. The proposed system is very important in schools, colleges and also any kinds of classes. Operation of this automatic instrument (electronic bell) must have to be executed with an accurate time controller in an inexpensive way. Electronic automatic bell system is designed for school/college bells to make school/college bells automated. The primary objective of designing this project is to reduce the human intervention for the purpose of manual switching operation of a bell. Because of this manual switching we are having an improper and inaccurate operation of time. So, a system should be designed in such a way that it is exactly dependent on the real time clock and the switching of the bell should be controlled automatically without human intervention. In addition, the system should be designed in such a way that we can store the schedule of whole day or week and able to change it as per our requirement. Moreover, the use of this device for multi-stored and large-scale schools and colleges will play a very beneficial role.

## II. Literature Review

In recent decades, several school/college bell systems have been tested, some proving more functional than others traditional electronic bell. Several schools have tried using sirens and klaxons to alert students and teachers of period times, nevertheless these were usually found to be stressful, and had an adverse effect on the concentration ability of students. The colleges/ schools, where the teaching section can span over eight periods including breaks that the bell rings at the start of each period without any human intervention to a great degree of accuracy and hence takes over the manual task of switching on/off the college bell with respect to time. The bell rings at the start of each period without any human intervention to a great degree of accuracy and hence takes over the manual task of switching on/off the college bell with respect to time. Microcontroller has to be programmed using the C language or assembly language for controlling the circuit and it uses Real Time Clock (DS1307) which tracks the real time [1][2].

Circuit uses a programmed microcontroller chip to schedule the school teaching and break periods so that for every start or end of a period a bell is automatically rang. This design finds a tremendous use at primary and secondary school levels where the teaching sections can span over eight periods including breaks [4][5]. Another Arduino based college bell circuit used three major components which are IC RTCDS1307, Arduino Uno Board, and 16x2 LCD modules. Arduino is used for reading time from ds1307 and display it on 16x2 LCD. A buzzer is also used for alarm indication, which beeps when alarm is activated, simultaneously voice module will read out the data displayed on the LCD module [3]. While there are solutions available in market to automate this task, they are also cumbersome to operate and overpriced for the limited features they offer. They use DS3231 RTC module for timekeeping and HC-05 Bluetooth module for wireless communication. This design provides multiple time table setting features along with an elaborate event holding capacity which is far more versatile than the timer system commercially available in the market [6].

One research is carried out through two stages of design. The first stage is the stage of hardware design. The second stage is the stage of software design. Programs are made using the Basic programming language using the Bascom-AVR application. The results of the product were tested using the black box method with two stages. In the first stage, software testing uses a series of simulations on the Proteus 7 Professional application. The second stage is testing hardware [7]. A high accurate school bell controller based on ESP32 and DS3231 Real Time Clock module implemented with using Wi-Fi to correct the system time whenever switched OFF and ON despite of that the accuracy of the DS3231 RTC is  $\pm 40$  seconds per year with the absence of the Internet. The Bluetooth part of ESP32 is used to configure the system by inserting timetable of the school, the time delay for ringing bell, offset time for the country, and configuring SSID and PASS of the router [8]. An electric bell is used as alarm, which will ring when the alarm is activated, and so the date and time will be displayed on the LCD module. The bell would continue to ring for 10 seconds in every block of our college simultaneously by transferring the information via IoT, which will indicate the students and faculty of the institutions about the completion of a particular session in all the blocks in a simultaneous manner [9]. The bell rings at the start of every period without any human intervention to a great degree of accuracy and hence succeeds the manual task of switching on/off the college bell on-time. This project uses LAN to work. Both Hardware and the App should be connected to the same Wi-Fi network [10].

The system was developed speakers are connected wirelessly and timing of bell and national anthem are programmable. The transmitter side consists of a zigbee connected to computer and GUI is used to control the timing of bell, national anthem. The receiver consists of controller and zigbee and LCD display. The college bell is a simple project implementing the use in real time with its properties as an alarm with further more improvements [11][12]. Low power automatic bell which can be used in educational institutions and the power estimation details. The bell automatically rings at preprogrammed time intervals and also displays the time in the seven segment display continuously. The low power aspect is brought about by using 'SLEEP' mode in PIC microcontroller which keeps the system in idle state when it is not in use [13]. GSM module are use for sending and receiving the message, once the period is set, GSM module sends message to that particular faculty, when class begins; It additionally changes the information in the notice board through straightforward SMS [14].

### III. Working Methodology

The total system is designed in four basic parts. Firstly, the power supplies that supply power all of circuits. Secondly (RTC) real time digital clock circuit with which time data has been taken. Then the main controller part is design with microcontroller and the last part of the system is amplifier circuit and sound unit and it is the main output section of this proposed system. The circuit concept is quite simple. First AC current to the pin is plugged into the primary part of the transformer. The primary part of the transformer has been rated at 220 volts and the secondary part has been converted 220 volts to 12 volts. A full wave bridge rectifier gives 12 volts AC voltage to 12 volts DC voltage. From that 12 volts DC to 5 volts by voltage regulator IC has been generated. By which the digital voltage of the circuit is given. The first part of the circuit contains a real time digital clock circuit. Data from that digital clock is taken to a controller circuit. With that circuit there are buttons to select time for classes, which time can be selected as desired there will be a pin out of the controller circuit according to the time that will be selected in the segment. Connected to a sound is given to the speaker via an amplifier. The amplifier comes with a microphone that can be used to send voice to the speaker.

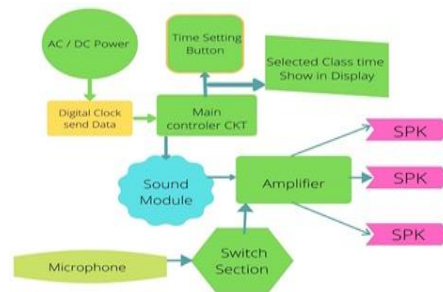

Fig. 1. Flow Chart of the Proposed System.

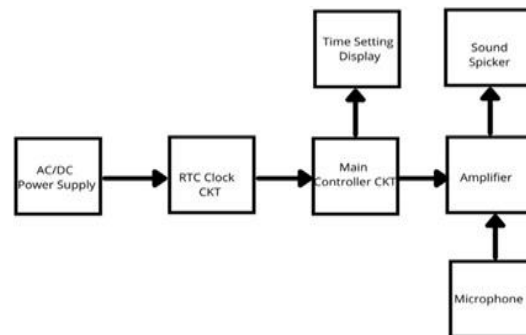

Fig. 2. Block Diagram of the Proposed System.

#### IV. Working Principle

The operation of the proposed system is very simple. To install the device in a class, one speaker should be installed in each class. The main device should be set in a specific place, in which case it is better to have a head teacher's room. The amplifier attached to the device must be parallel to each speaker. The first digital clock is kept to see the time and the data of the main controller circuit becomes this socket. Then the specific time is set for the bell in the main controller circuit, and then the output comes to the controller circuit at that set time. f) Later that output is given to a sound module. A sound module is connected to an amplifier. Then the sound goes from that amplifier to the speaker that is installed in the classroom. And it goes at the time that is set.

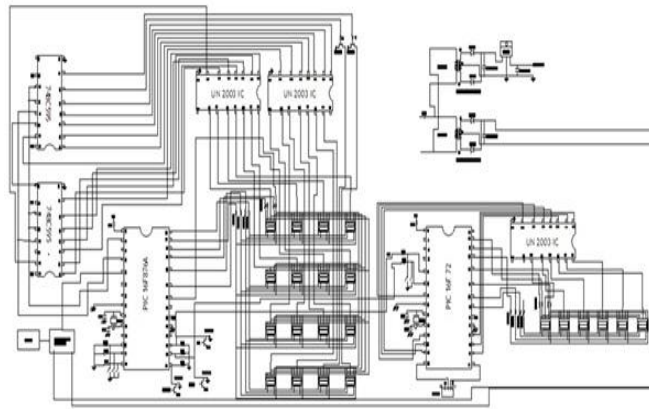

Fig. 3. Circuit Diagram of Proposed System.

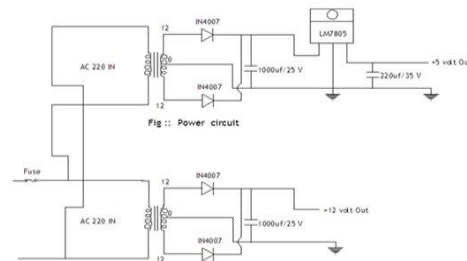

Fig. 4. Circuit Diagram of power Section.

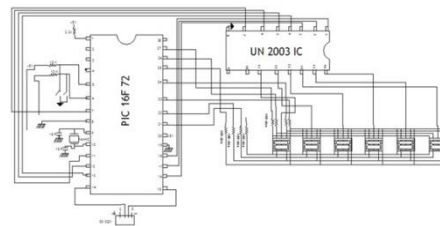

Fig. 5. Circuit Diagram of Clock Section

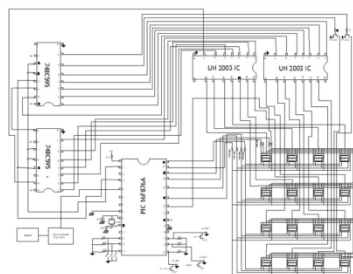

Fig. 6. Circuit Diagram of Control Section

#### V. Practical Implementation

In the first stage we completed the whole project program with micro c. Then we tested the project at the Computers electronics software Lab Centre Portions. Then we setup the physical construction of the project. After that we passed that program through the computer to the microcontroller IC using a writer. Then we powered the circuit, digital clock circuit and all the parts are integrated in the circuit according to the controller diagram. We checked the digital clock first then checked the main controller

circuit. Then we set three times in the controller circuit. When the time is set, we can hear the speaker's sound through the amplifier through the sound module according to those three times. Lastly, we checked the sound on the speakers by connecting a microphone with amplifier.

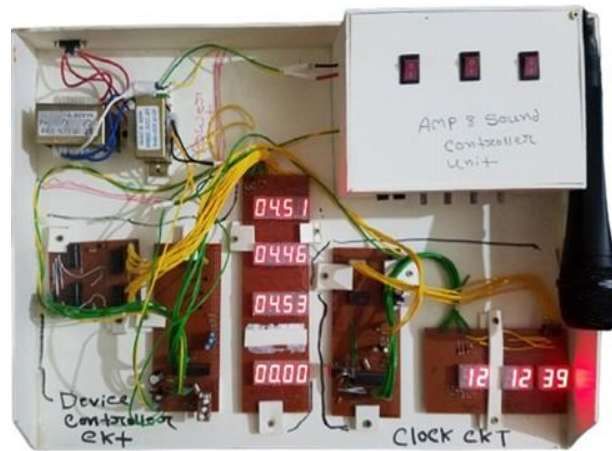

Fig. 7. Real time Project circuit.

## VI. Result Analysis

After implementing all the components in electronic strip board, we tested the projects step by step and got the expected results. After giving power supply to the kit, firstly we checked the digital clock, and the digital clock is working properly. Then we set the main controller circuit three times. The speakers also rang according to the set three times. Finally we attached the microphone to the amplifier and checked that it was ringing. We written the program in such a way that the bell should ring simultaneously in every 60 minutes, and the project was functioned as per expected.

Table 1. Cost Calculation of the Project

Description	Quantity	Price (BDT)
AC Power Cable	1	50
Transformer 12 volt (Step Down)	2	300
Microcontroller (16F72)	1	190
Microcontroller (16F876A)	1	100
748C595 Shift Resister	2	100
UN 2003IC	3	60
Resistor	35	35
Capacitor	8	90
Display (Seven segment)	22	550
Amplifier Circuit	1	400
LED	1	3
Bray Board	6	180
Wire Faxable	120ft	250
Diode	5	5
DS 3231	1	180
PVC (5mm)	5ft	150
Transistor (2N22)	8	40
Super Glue	1	100
Others	-	100

## VII. Conclusion

Bells are a very significant to all educational institutions. It can manage and control class schedule with proper time slotting. This microcontroller based automatic bell system able to provide bells at specific time periods manage by authorized person. In this work, simple smart electronic school/college bell is developed using internal code which is fully meet the system's goal. The basic design provides an opportunity of selecting the suitable time schedule for every school by momentarily pressing one of the push-to-on switches. This signals the microcontroller to carry out the specific task, thereby ringing the bell at a regular time interval. Therefore, from the results obtained, it can be concluded that the aim of this work has been practically and theoretically achieved. In addition this electronic bell sound system is controllable; the authorized person can manage volume as per demand, and also this project can use alternative power source like, solar energy.

## References

1. Aman Tirpude, Mukul Trivedi, Dinesh Dangare and Namika Rodge, "Microcontroller Based Automatic College Bell" An International E-Journal on Emerging Trends in Science, Technology and Management, Vol. 2 : Issue 2 - February 2017.
2. Syed Naveed Uddin, Mohd Omer Nawaz, T.Kalinga Raj and Shaik Mahammed Rasool, "Automatic School Bell with User defined Time Schedule" International Journal of Advanced Research in Electrical, Electronics and Instrumentation Engineering, Vol. 6, Issue 2, February 2017.
3. Burgoji Santhosh Kumar, "Implementation of Automatic College Bell System Using Arduino" International Journal of Current Engineering and Scientific Research (IJCESR), Vol. 5, Issue 4, 2018.
4. Henry Ohiani Ohize, Elizabeth Nonye Onwuka and Ahmed Ibrahim, "Design of Microcontroller-Based Automatic School Bell" AU J.T. 15(2): 121 -128 (Oct. 2011).
5. Sheenu Choudhary, Srikant and Priyanka Sharma, "Automatic College Bell System" International Journal of Scientific Research and Management (IJSRM), Vol. 2, Issue 3, 2014.
6. Vaishnavi.D.R, Neha Khanum, Apoorva Singh A, Sumaya Afreen, "Automated College Bell System with Wireless Control" International Journal of Advanced Research in Electrical, Electronics and Instrumentation Engineering, Vol. 6, Issue 5, May 2017.
7. Muhammad Sabri Annas, Haripuddin, Satria Gunawan Zain, "Microcontroller Implementation for Automatic Smart Bell" International Journal of Environment, Engineering & Education, Vol. 1, No. 1, 2019.
8. Riyadh Zaghlool Mahmood, "High Accurate Automatic School Bell Controller Based On ESP-32 Wi-Fi" Technium, Vol. 4, No.10, 2022.
9. Nalini, Naveen Raj, Sharwanjana, Satish Kumar and Vijay, "IOT Based Wireless Automated Bell Ringing System in an Institution" International Journal of Creative Research Thoughts (IJCRT), Volume 8, Issue 3 March 2020.
10. S.Arockia Ranjith Kumar, R.Glarwin, M.Gowthamaraj, M.K.Vijayanainar, G.Shunmugalakshmi, "Iot Based Automatic College Gong" International Journal of Scientific & Technology Research, Vol. 9, Issue 3, March 2020.
11. Prof: D. K. Shah, "Automatic Wireless College Bell System Using Zigbee" Journal of Emerging Technologies and Innovative Research (JETIR), Vol. 6, Issue 5, May 2019.
12. Abyash Gautam, Deepak Rasaily, Sejal Dahal, "Microcontroller Controlled Automated College Bell" International Journal of Engineering Trends and Technology (IJETT), Vol. 32 Number 4, February 2016.
13. Rajesh Kannan Megalingam, Venkat Krishnan Balasubramanian, Mithun Muralidharan Nair, Vineeth Sarma Venugopala Sarma and Rahul Srikumar, "Power Aware Automatic Microcontroller Based Smart, College Electric Bell System with Time Display" Fifth International Conference on MEMS NANO, and Smart Systems, DOI 10.1109/ICMENS.2009.41.
14. A.Venkateswara rao, Y.Naveen, B.Sai Upendra,U.Rajesh Gupta, P.Hemanth kumar, "College Time Table and Notice Board Display With Auto SMS to Faculty" Journal of Engineering Sciences, Vol. 12, Issue 9, September 2021.
15. Mykepredko, "Programming and Customizing the PIC Microcontroller" Published by Tata McGraw -Hill, Date of Published: 2007
16. Michael Crichton Richard Preston, "Micro (novel): Science fiction, Adventure, techno-thriller" Published by HarperCollins. Date of Published: November 22, 2011.